

**LIFE TOGETHER**  
**Living as the Family of God**  
**Healthy Marriages**  
**1 Peter 3:1-7**

**Crosspoint Church Demographics**

<b>Age</b>		
Age	Count	%
18-22	135	22%
23-29	136	22%
30's	105	17%
40's	56	9%
50's	93	15%
60's	71	11%
70's	22	4%
80's	1	0%
High School	6	1%
<b>Grand Total</b>	<b>625</b>	
<b>49 &amp; Under</b>	<b>438</b>	<b>70%</b>
<b>50 &amp; Over</b>	<b>187</b>	<b>30%</b>

<b>Gender</b>		
Gender	Count	%
Female	331	53%
Male	294	47%
<b>Grand Total</b>	<b>625</b>	

<b>Marital Status</b>		
Age	Count	%
Married	383	61%
Unmarried	242	39%
<b>Grand Total</b>	<b>625</b>	

**Baptist Faith and Message 2000 - XVIII. The Family**

God has ordained the family as the foundational institution of human society. It is composed persons related to one another by marriage, blood, or adoption. Marriage is the uniting of one man and one woman in covenant commitment for a lifetime. It is God's unique gift to provide for the man and the woman in marriage the framework for intimate companionship, the channel for sexual expression according to biblical standards, and the means for procreation of the human race.

The husband and wife are of equal worth before God, since both are created in God's image. The marriage relationship models the way God relates to His people. A husband is to love his wife as Christ loved the church. He has the God-given responsibility to provide for, to protect, and to lead his family. A wife is to submit herself graciously to the servant leadership of her husband even as the church willingly submits to the headship of Christ. She, being in the image of God as is her husband and thus equal to him, has the God-given responsibility to respect her husband and to serve as his helper in managing the household and nurturing the next generation. Children, from the moment of conception, are a blessing and heritage from the Lord. Parents are to demonstrate to their children God's pattern for marriage. Parents are to teach their children spiritual and moral values and to lead them, through consistent lifestyle example and loving discipline, to make choices based on biblical truth. Children are to honor and obey their parents.

**How do we have healthy marriages?** By husbands and wives living out their roles by the grace of God.

### Dovetail

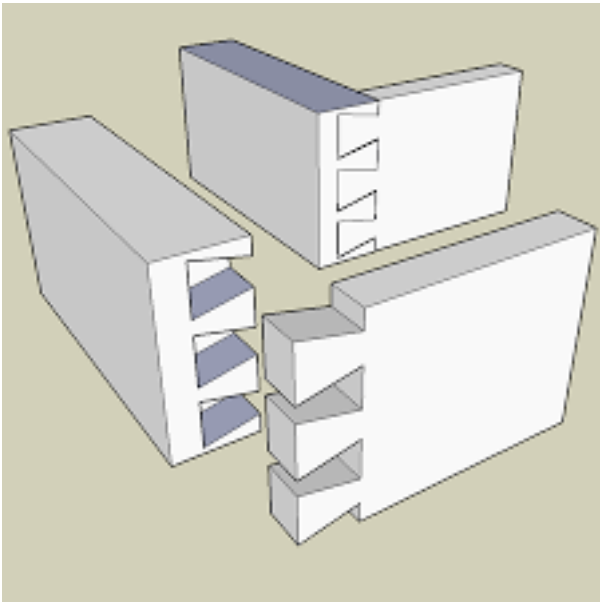

### The context is submission (2:13-3:6)

- (1) Submission to the government (2:13-18)
- (2) Submission of slaves to masters (2:18-20)
- (3) Submission of wives to their husbands (3:1-6)

### I. Wives (3:1-6)

#### A. Submit to your husbands (4:1-2)

- Submission is . . .

- (1) Spiritual (1 Pet. 3:1-2; Eph. 5:21, 22-24, 33; Col. 3:18)

#### Eph. 5:22-24

Wives, submit to your own husbands, as to the Lord. 23 For the husband is the head of the wife even as Christ is the head of the church, his body, and is himself its Savior. 24 Now as the church submits to Christ, so also wives should submit in everything to their husbands.

- Submission is not determined by the worthiness of the person we submit to, but the worthiness of the person who calls us to submit.

- (2) Specific (v. 1a) **“be subject to your own husbands”**

- (3) Voluntary - Your submission in marriage is a gift offered, not a duty coerced.

**What submission does mean (John Piper):**

“Submission is the divine calling of a wife to honor and affirm her husband’s leadership and help carry it through according to her gifts. It’s the disposition to follow a husband’s authority and an inclination to yield to his leadership. It is an attitude that says, “I delight for you to take the initiative in our family. I am glad when you take responsibility for things and lead with love. I don’t flourish in the relationship when you are passive and I have to make sure the family works.”

▪ **Submission is not . . .**

- (1) Submission is not a contradiction of our equality in Christ.
  - Men and women are equally made in the image of God (Gen 1:26-27)
  - They have equal access to salvation (Gal. 3:28)
  - They share the same destiny (1 Peter 3:7)
  - The same Paul who spoke of equality in Gal. 3:28 commanded submission in Eph. 5:22-33
  - Peter teaches the equality of women 3:7 and encourages submission 3:1
- (2) Submission is not putting a husband in the place of Christ.
- (3) Submission is not giving up independent thought.
- (4) Submission is not giving up efforts to influence and guide her husband.
- (5) Submission is not giving in to every demand of her husband.
- (6) Submission is not based on lesser intelligence or competence.
- (7) Submission is not being fearful or timid – she is not to act out of fear.
- (8) Submission is not determined by the behavior of a husband.

> **Two views of gender roles:**

- (1) **Egalitarianism** - The fall corrupted and introduced a subordinate role - Christ came to reverse the fall.
- (2) **Complementariansim** -The fall corrupted the gender roles - Christ came to restore the divine order of original creation.

The curse brought a distortion of previous roles, not the introduction of new roles. God establishes the woman’s subordinate role not in the Fall, but in the divine order of original creation. The differences of manhood and womanhood is God’s idea. The differences are not the result of sin. Sin did not bring diversified, complementary roles into existence. God did! At creation God made Adam to be a loving, caring, strong leader for his wife Eve. God created Eve to be a supporter and honor his leadership. Equal in personhood, both made in the image of God. In the home it is to be lived out between a husband and wife.

**Wayne Grudem**

	<u>What sin ruined</u>	
<u>Errors of passivity</u>	<u>Biblical Ideal</u>	<u>Errors of aggressiveness</u>
<b>Husband</b> > Wimp	Loving, humble, servant headship	Tyrant
<b>Wife</b> > Doormat	Joyful, intelligent submission	Usurper

▪ **Submission displays the gospel (3:1b-2)**

1b.so that even if some do not obey the word, they may be won without a word by the conduct of their wives, 2 when they see your respectful and pure conduct.

▪ **Submission reflects Christ (2:21-24; Phil. 2:5-11)**

**1 Peter 2:21–24**

21 For to this you have been called, because Christ also suffered for you, leaving you an example, so that you might follow in his steps. 22 He committed no sin, neither was deceit found in his mouth. 23 When he was reviled, he did not revile in return; when he suffered, he did not threaten, but continued entrusting himself to him who judges justly.

**Philippians 2:5-11**

5 Have this mind among yourselves, which is yours in Christ Jesus, 6 who, though he was in the form of God, did not count equality with God a thing to be grasped, 7 but emptied himself, by taking the form of a servant, being born in the likeness of men. 8 And being found in human form, he humbled himself by becoming obedient to the point of death, even death on a cross. 9 Therefore God has highly exalted him and bestowed on him the name that is above every name, 10 so that at the name of Jesus every knee should bow, in heaven and on earth and under the earth, 11 and every tongue confess that Jesus Christ is Lord, to the glory of God the Father

- The Son takes a subordinate role, and in that movement he shows not his weakness but his greatness.

This passage is not an assault on the dignity and divinity (but rather led to the greater glory) of the second person of the Godhead to submit himself, and assume the role of a servant, then how could it possibly injure me to be asked to play out the “Jesus role” in my marriage?

**Kathy Keller – *The Meaning of Marriage*, p. 175**

**B. Value what God values (vv. 3-4)**

3 Do not let your adorning be external—the braiding of hair and the putting on of gold jewelry, or the clothing you wear— 4 but let your adorning be the hidden person of the heart with the imperishable beauty of a gentle and quiet spirit, which in God’s sight is very precious.

**1 Timothy 2:9–11**

9 likewise also that women should adorn themselves in respectable apparel, with modesty and self-control, not with braided hair and gold or pearls or costly attire, 10 but with what is proper for women who profess godliness—with good works. 11 Let a woman learn quietly with all submissiveness.

**C. Place your hope in God (vv. 5-6)**

5 For this is how the holy women who hoped in God used to adorn themselves, by submitting to their own husbands, 5 For this is how the holy women who hoped in God used to adorn themselves, by submitting to their own husbands, 6 as Sarah obeyed Abraham, calling him lord. And you are her children, if you do good and do not fear anything that is frightening.

▪ **Submission starts with hope in God.**

- Because these holy women hoped in God they adorned themselves with a gentle and quiet spirit that lead them to submit to their husbands.

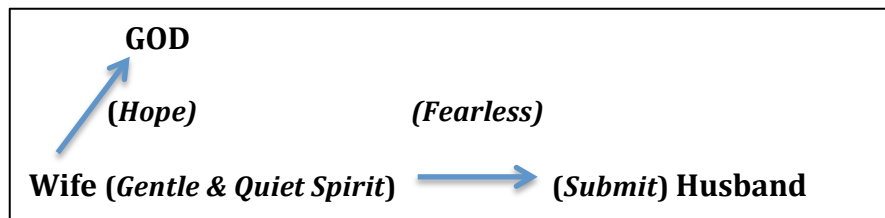

▪ **The presence of hope drives out fear (v. 6b).**

And you are her children, if you do good and do not fear anything that is frightening.

So this portrait of Christian womanhood is marked first by hope in God and then what grows out of that hope, namely, fearlessness. She does not fear the future; she laughs at the future.

The presence of hope in the invincible sovereignty of God drives out fear. Or to say it more carefully and realistically, the daughters of Sarah fight the anxiety that rises in their hearts.

They wage war on fear, and they defeat it with hope in the promises of God.

**John Piper**

▪ **Hope comes from knowing God and his promises.**

**Romans 15:4**

For whatever was written in former days was written for our instruction, that through endurance and through the encouragement of the Scriptures we might have hope.

**Are you acquainted with the character of the Promiser and the specifics of his promises?**