

# BEGINNING MINISTRY

## Acts 3

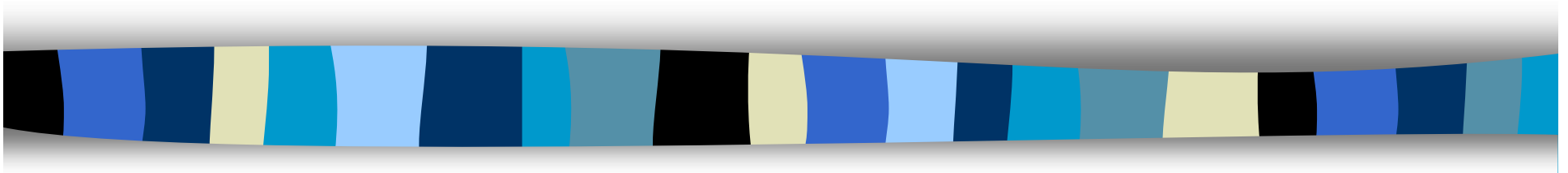

JoLynn Gower  
jrgower@aol.com  
352-2458



# PRAYER TIMES

- Frequently devout Jews went to the temple to pray
- Prayer times were 9:00 AM, 3:00 PM, and sunset
- Since Jews began the day at 6:00 AM, the 9<sup>th</sup> hour would have been the 3:00 PM prayer time
- People who were disabled/ill frequently sat at the spots frequented by people going to worship
- Beautiful gate—Nicanor gate—Corinthian gate
- Nicanor apparently financed (or made) the gate
- Ossuary found on the Mt. of Olives with the inscription: "The bones of Nicanor the Alexandrian, who made the doors."

# WHERE WAS THE GATE?



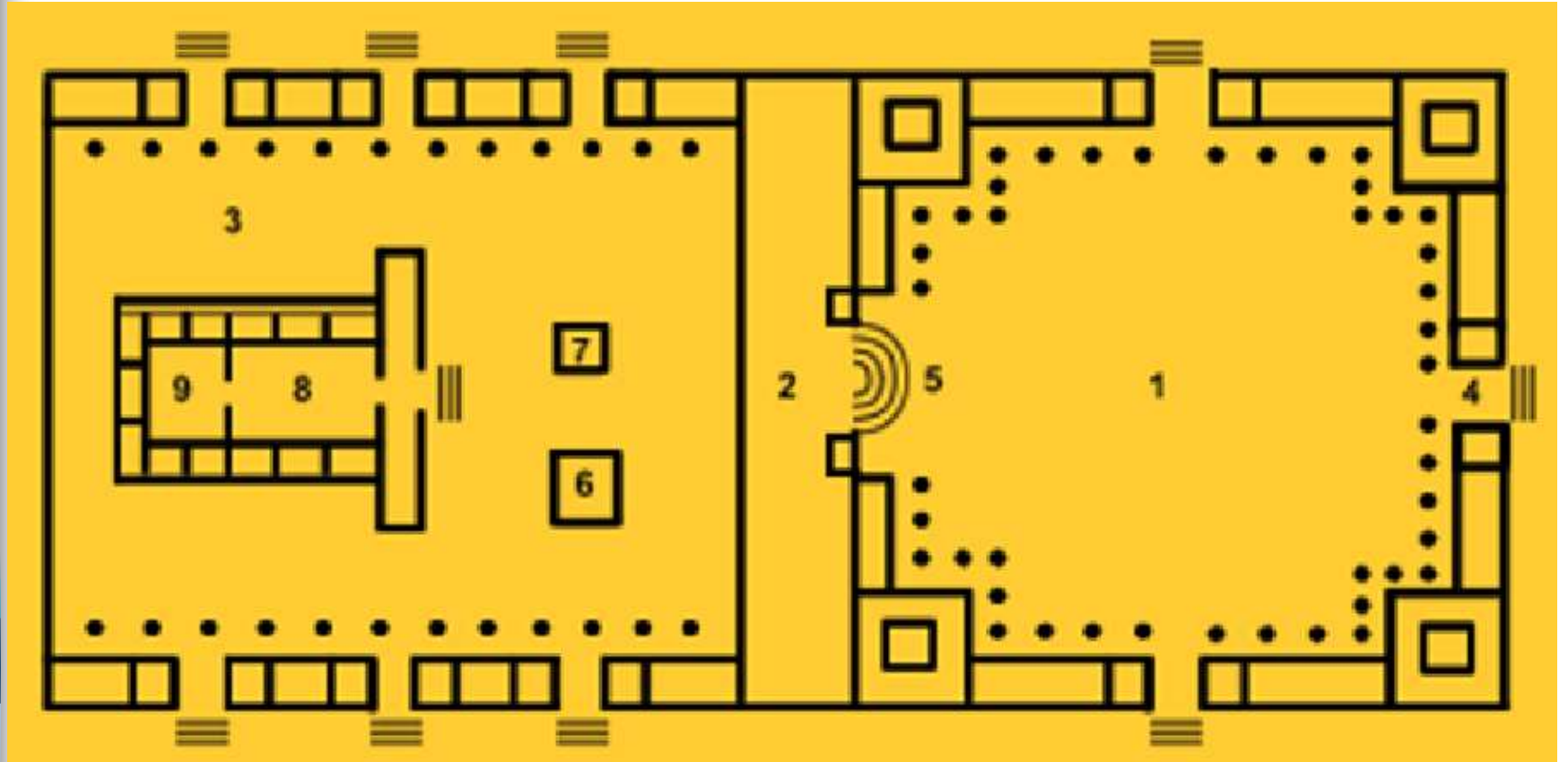

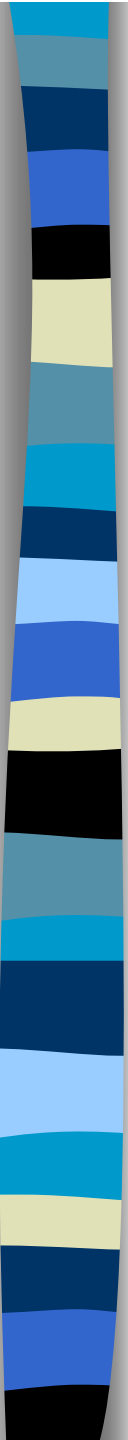



# THE MAN

- Lame from birth
- Used to beg “every day” for alms
- **Alms: *eleemosune*: compassion, charity**
- Peter fixed his gaze: *atenizo*: looked intently
- The man didn’t ask to be healed
- Peter didn’t ask if he wanted to be healed
- **Acts 3:6 But Peter said, "I do not possess silver and gold, but what I do have I give to you: In the name of Jesus Christ the Nazarene—walk!"**
- Name: *onoma*: name, authority, cause
- The occasion drew a crowd

# SOLOMON'S PORTICO

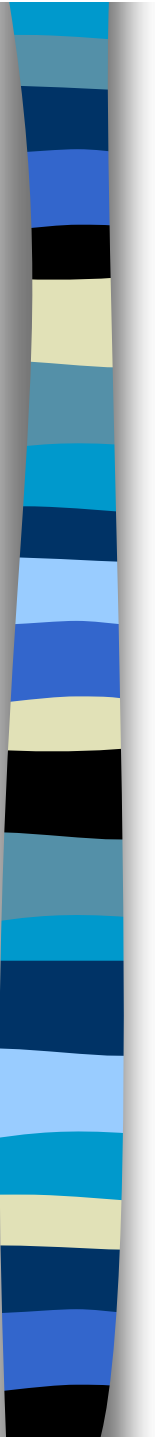



# PETER'S SECOND SERMON

- Acts 3:12 But when Peter saw this, he replied to the people, "Men of Israel, why are you amazed at this, or why do you gaze at us, as if by our own power or piety we had made him walk?"
- Peter knows that the power didn't come from him
- He also knows that he isn't pious enough to deserve it
- **Piety: *eusebeia*: piety, godliness, holiness**
- Acts 3:13 "The God of Abraham, Isaac and Jacob, the God of our fathers, has glorified His servant Jesus, the one whom you delivered and disowned in the presence of Pilate, when he had decided to release Him."





# RECALLING EVENTS

- Acts 3:14-16 "But you disowned the Holy and Righteous One and asked for a murderer to be granted to you, but put to death the Prince of life, the one whom God raised from the dead, a fact to which we are witnesses. And on the basis of faith in His name, it is the name of Jesus which has strengthened this man whom you see and know; and the faith which comes through Him has given him this perfect health in the presence of you all.
- Matthew 27:15-17 Now at the feast the governor was accustomed to release for the people any one prisoner whom they wanted. At that time they were holding a notorious prisoner, called Barabbas. So when the people gathered together, Pilate said to them, "Whom do you want me to release for you? Barabbas, or Jesus who is called Christ?"



# ACTING IN IGNORANCE

- Acts 3:17 "And now, brethren, I know that you acted in ignorance, just as your rulers did also."
- Jews regarded willful sin as worse than unintentional sin
- Numbers 15:30 "But the person who does anything defiantly, whether he is native or an alien, that one is blaspheming the Lord; and that person shall be cut off from among his people."
- Deception was considered a sin of ignorance
- Peter was telling them that there was still an opportunity to repent



# SUFFERING FULFILLED PROPHECY

- Acts 3:18 But the things which God announced beforehand by the mouth of all the prophets, that His Christ would suffer, He has thus fulfilled.
- Isaiah 53:3-5 He was despised and forsaken of men, a man of sorrows and acquainted with grief; And like one from whom men hide their face, He was despised, and we did not esteem Him. Surely our griefs He Himself bore, and our sorrows He carried; Yet we ourselves esteemed Him stricken, smitten of God, and afflicted. But He was pierced through for our transgressions, He was crushed for our iniquities; The chastening for our well-being fell upon Him, and by His scourging we are healed.
- What happened was sinful and wrong; however, God knew that it would happen



# WHAT WAS EXPECTED

- The man expected (or hoped) to get some money or at least some stuff
- He actually received something better
- This should be a sign to everyone that prophecy is being fulfilled in their midst
- **Acts 3:22-26** "Moses said, 'The Lord God will raise up for you a prophet like me from your brethren; to Him you shall give heed to everything He says to you. 'And it will be that every soul that does not heed that prophet shall be utterly destroyed from among the people.' And likewise, all the prophets who have spoken, from Samuel and his successors onward, also announced these days. It is you who are the sons of the prophets and of the covenant which God made with your fathers, saying to Abraham, 'And in your seed all the families of the earth shall be blessed.' For you first, God raised up His Servant and sent Him to bless you by turning every one of you from your wicked ways."